

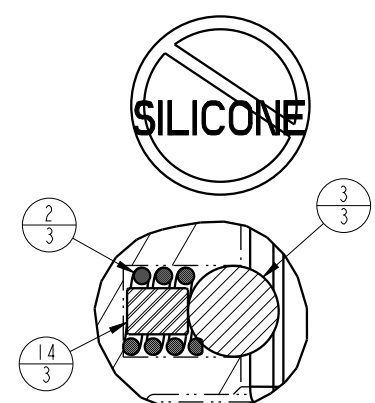

NO	QTY	PART NO	DESCRIPTION	SEAL KIT
1	1	21510002	NUT, JAM, HEX, M12-1.50	
2	3	23350086	SPRING, COMPRESSION	X
3	3	23650010	BALL, TUNGSTEN-CARBIDE, 6mm	X
4	2	39051079	O-RING, (6mm X 1)	X
5	1	39051083	O-RING, (41mm X 2)	X
6	2	39051087	O-RING, (4mm X 3)	X
7	1	39053043	SEAL, WIPER, SNAP IN, WED, 22, 94A, AU	X
8	1	39056003	SEAL, STEP, ROD, 22	X
9	1	39056023	SEAL, CAP, PISTON, 40, 90A, AU GRPHT FLD	X
10	2	43068004	PLUG, SOCH, G1/8	
11	1	81400143	PLUNGER, SC, 7MPa, 40B, RH	
12	1	81400153	CAP, LC/SC, 7MPa, 40B	
13	2	81400200	PLUG, MANIFOLD, 7MPa, M6	
14	3	81400203	PIN, STOP, BALL, METRIC, 6mm BALL	X
N/A	N/A	L6014400	KIT, SEAL, SC, 7MPa, 40B	NOTED

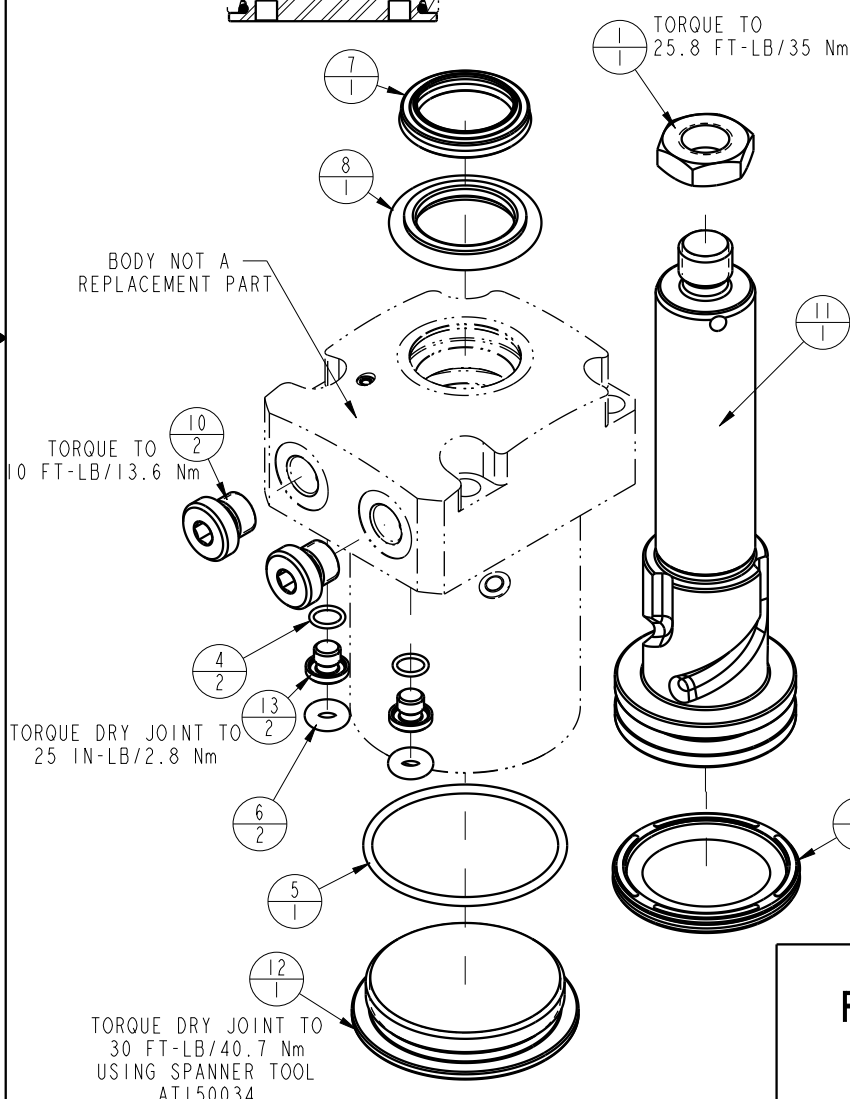

DETAIL A
SCALE 2.000
USE GREASE TO HOLD SPRING, STOP PIN, & BALL IN BODY PRIOR TO INSTALLING PLUNGER

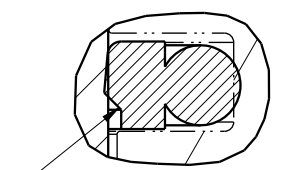

DETAIL B
SCALE 3.000

PARTS LIST	 VEKTEK, INC. 1334 E. SIXTH AVE. P.O. BOX 625 EMPORIA, KS. 66801 U.S.A.
	ASSEMBLIES AFFECTED L140400R
PARTS LIST, ASSY, SC, TF, 7MPa, 40B, RH	SIZE A LPL1405
REV B	REV B

B	3273	RELEASE	JDW	08/15/18
REV	IN ACCORDANCE WITH ECN	EFFECTIVE DATE	REVISED BY	DATE
DRW BY:	QMITCHELL	DRAWING STATUS: Released		
DATE:	7-17-13	PRODUCTION APPROVED FOR RELEASED STATUS ONLY		